

# HakkiFeed

## 422

### Hydraulic log rack

- Operating, assembly and maintenance manual
- Spare parts manual
- EC Declaration of Conformity
- Safety instructions
- Guarantee terms



**The operator must read and understand these instructions before operating the machine!**

*MAASELÄN KONE OY*  
Valimotie 1, FI-85800 Haapajärvi  
Tel. +358 (0)8 772 7300  
[info@hakkipilke.fi](mailto:info@hakkipilke.fi)  
[www.hakkipilke.fi](http://www.hakkipilke.fi)

## Table of contents

1. General information.....	3
1.1. Introduction.....	3
1.2. Purpose of use.....	3
1.3. Operating conditions.....	3
1.4. Safety instructions.....	3
2. Receipt and assembly.....	4
2.1. Delivery inspection.....	4
2.2. Assembly instructions.....	4
2.3. Lifting and moving the machine.....	4
2.4. Main components of the machine.....	5
3. Control functions and setting up the machine.....	5
3.1st Arranging the machine for operation and transport.....	5
3.1.1. Adjustments.....	5
3.1.2. Connecting the hydraulics.....	6
4. Operating the machine.....	6
4.1st Performing a test run on the machine.....	6
4.2nd Loading logs onto the log rack.....	7
5. Machine maintenance.....	7
5.1. Tightening.....	7
5.2. Lubrication.....	7
5.3. Washing and cleaning.....	9
6. Storage.....	9
7. Maintenance table.....	9
8. Failures and remedial measures.....	9
9. Assembly instructions and spare parts diagrams.....	10
9.1. Parts list for the assembly.....	10
9.2. Assembly phases.....	11
10. Guarantee terms.....	18
11. Declaration of incorporation for partly completed machinery.....	19

## 1. General information

### 1.1. Introduction

The purpose of this manual is to ensure that the machine is used in the manner intended by the manufacturer, taking safety into consideration. Everyone operating the machine or working in close proximity to it must study this manual carefully.

Before commencing work, operators must also familiarise themselves with the machine's control and safety equipment, and ensure their proper operation.

Additional information on Maaselän Kone Oy's products is available on our website at [www.hakkipilke.fi](http://www.hakkipilke.fi).

**Keep this manual in the immediate vicinity of the machine.**

### 1.2. Purpose of use

The HakkiFeed 422 log rack is intended for moving pruned wood or logs onto a Hakki Pilke firewood processor. The firewood processor must not be used to process any treated wood, such as is found in construction waste.

The maximum diameter of the logs to be processed is 40 cm. This limit must not be exceeded. The maximum length of the logs to be placed on the rack is 4 metres, and the minimum length is 2 metres.

#### Machine models and basic information

Model	HakkiFeed 422 (accessory, Hakki Pilke)
Driving power	Hakki Pilke firewood processor's hydraulics (max 200 bar, max 16 l/min)
Weight	330 kg
Height/width/length	(mm)
Max log diameter	40 cm
Max/min log length	4,000 mm–2,000 mm
Max load-bearing capacity	2,000 kg

The machine's serial number, year of manufacture, weight and model are provided on the grey type plate fixed to the machine's frame. (Figure)

### 1.3. Operating conditions

- The temperature range within which the machine can be operated is -20 to +30 °C. In the winter, the operator must ensure that there is no risk of slipping in the working area.
- The working area must be level and clear of unnecessary items. No unauthorised persons may enter the working area. The machine may only be used in sufficient lighting conditions.

### 1.4. Safety instructions

- This machine is intended to be operated by only one operator. The danger zone is 10 metres around the machine.
- Persons under 18 years of age may not operate the machine.
- The operator must ensure that the use of the device does not cause danger to others and that there are no unauthorised persons in the danger zone.

- The machine may not be operated while under the influence of alcohol or other drugs, or when tired.
- The machine may not be operated unless the operator has familiarised themselves with this instruction manual.
- The machine is only intended for transferring logs to the Hakki Pilke firewood processor.
- The operator is not permitted to modify the structure or operation of the machine or remove protective equipment.
- The operator must wear ear protectors, sufficiently tight-fitting work clothing and gloves, protective goggles and safety footwear.
- Before starting up the machine, the operator must ensure that the machine and its guards are intact.
- When cleaning the machine or carrying out any maintenance, it must be disconnected from its power source.

## 2. Receipt and assembly

### 2.1. Delivery inspection

Dispose of the packaging material in an environmentally friendly manner.

Check that the machine has not sustained any damage during transit, and ensure that all necessary parts are included in the package. In the event of any defects or damage, contact the retailer immediately.

### 2.2. Assembly instructions

The rack can be delivered either assembled or packaged. If the rack is delivered in packaged form, a sufficiently proficient person must assemble it before use in accordance with the assembly instructions.

### 2.3. Lifting and moving the machine

When moving the machine, make sure that the moving and lifting capacity of your tractor or forklift is sufficient for the weight of the machine. Ensure the sufficient length of the lifting prongs so that the tips rest safely under both frame plates (Figure 1). Only lift the rack when it is empty and use the lifting points shown in **Figure 1**.

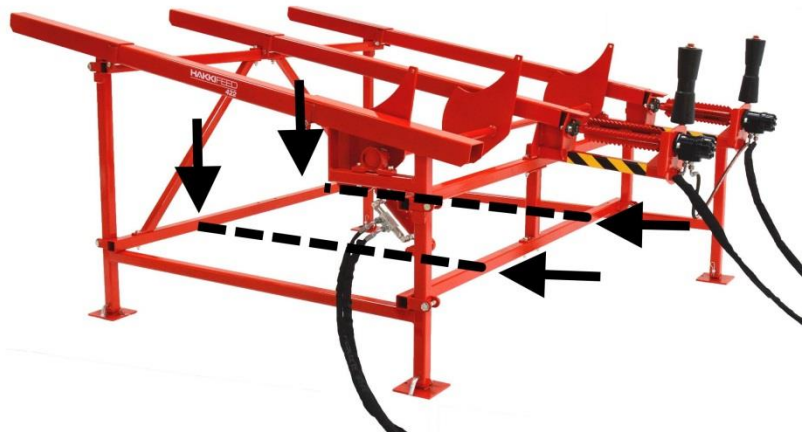

*Figure 1. Lifting points of the machine*

**Note! Incorrect lifting may cause a hazardous situation or damage the machine.**

## 2.4. Main components of the machine

The HakkiFeed 422 log rack is an accessory for the Hakki Pilke firewood processor. It is controlled hydraulically with the operating levers of the Hakki Pilke firewood processor's control unit.

- A. In-feed conveyor
- B. Log table
- C. Feeder

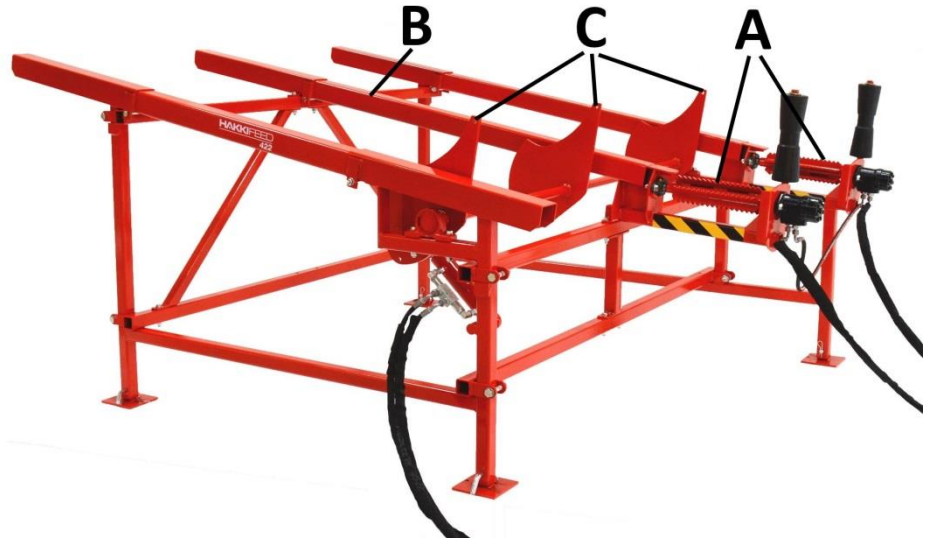

Figure 2. Main components of the machine

## 3. Control functions and setting up the machine

### 3.1. Arranging the machine for operation and transport

Before arranging the machine for operation and using it, ensure that the operating conditions, detailed in Section 1.4, are met and review the safety instructions in Section 1.5.

When preparing the rack for operation, ensure that it is positioned on an even and firm foundation so that the logs on the rack are straight. Ensure that the rack cannot move or slide on its foundation during use. Make sure that the machine's hydraulic hoses cannot be caught between moving parts or cause a hazard.

When arranging the rack for transport, clear any wood off of it and fix the hydraulic hoses to it with cable ties, for example.

**Note! Inspect and clean the machine before arranging it for transport.**

#### 3.1.1. Adjustments

Adjust the height of the rack according to the firewood processor model in such a way that the rack's in-feed conveyor A is at least 20 mm higher than the machine's in-feed belt. Adjust the distance between the machine and rack to ensure the safe transfer of logs to the machine. The maximum allowed distance between the rack and the machine's in-feed arrangement is 500 mm.

### 3.1.2. Connecting the hydraulics

**Use the operator's manual of the relevant Hakki Pilke firewood processor for the connections!**

Use of the rack requires two separate control valves: Example **Figure 3**.

**In-feed conveyor A** (Figure 1)

- Connected in series to the Hakki Pilke firewood processor's in-feed system (quick couplings **C** (red) and **D** (black))

**Note!** If the machine features the valve shown in Figure 3, it must be opened to ensure oil flow through the quick couplings.



*Figure 3.*

**Feeder C** (Figure 1)

- Connected to the accessory valve of the Hakki Pilke firewood processor (quick couplings **A** (red) and **B** (black))

Ensure that all connections are safe and secure!

## 4. Operating the machine

### 4.1. Performing a test run on the machine

The machine may not be used before a test run has been performed and all the functions of the machine have been tested. Both the test run and testing can only be performed by a person who has studied the machine's manual.

Before the test run, all of the components of the firewood processor must be checked. If any faults or wear and tear that may affect the safe use of the machine are discovered, the processor must not be used until the faulty or worn component is replaced and safe use can be ensured.

1. Make sure that you are familiar with the functions of the machine's controls. If necessary, see [Section 3](#).
2. Operate in-feed conveyor A ([Figure 2](#)) empty, and ensure that the rollers run freely and in the right direction.
3. Use feeder C unloaded and ensure that it can move freely in both directions.
4. Load logs onto table B, and use one log to test the operation before beginning actual work.

If a fault occurs during the test run, determine the cause of the fault and take remedial action as deemed necessary. The machine must be shut down and disconnected from the power source for the duration of both the diagnostics and repairs.

## 4.2. Loading logs onto the log rack

Use a forklift or tractor with a sufficiently long fork to ensure safe loading.

- Load the first log against the feeder – do not drop the log.
- Lower the following logs carefully on the rack – do not drop them.
- Load the logs on the machine with the stem end first, and ensure that the centre of gravity is in the middle so that the logs cannot tip to the side off the rack.
- Do not exceed the load-bearing capacity of the rack ([Section 1.3](#)), and leave enough room for the free operation of feeder C.
- Smaller logs can be stacked on top of each other, but a total height of 40 cm must not be exceeded.

**Note! Ensure that there are no other people in the vicinity of the machine when loading logs!**

**Note! Ensure that the log's centre of gravity stays on the conveyor!**

## 5. Machine maintenance

The machine must be disconnected from its power source before any maintenance, adjustment, replacement or cleaning measures. Only use spare parts that are supplied by the manufacturer or your retailer. If any of the machine's guards or components need to be removed for maintenance, they must always be reattached before the machine is activated. After maintenance and adjustment measures, a test run must be carried out on the machine, according to the instructions in Section 4.1.

### 5.1. Tightening

Check the tightness of the log rack bolts at regular intervals. Inspect the rack visually before each instance of use.

### 5.2. Lubrication

There are a total of six lubrication points in the machine, presented in the figures below.

1. In-feed conveyor bearings (B) 2 pcs, **Figure 6:B** (every 200 hours)
2. Feeder bearings (A) 2 pcs, **Figure 6:A** (every 200 hours)
3. Feeder cylinder nipples 2 pcs, **Figure 6:C** (every 50 hours)

**Note!** Take care when applying grease to dustproof bearings!



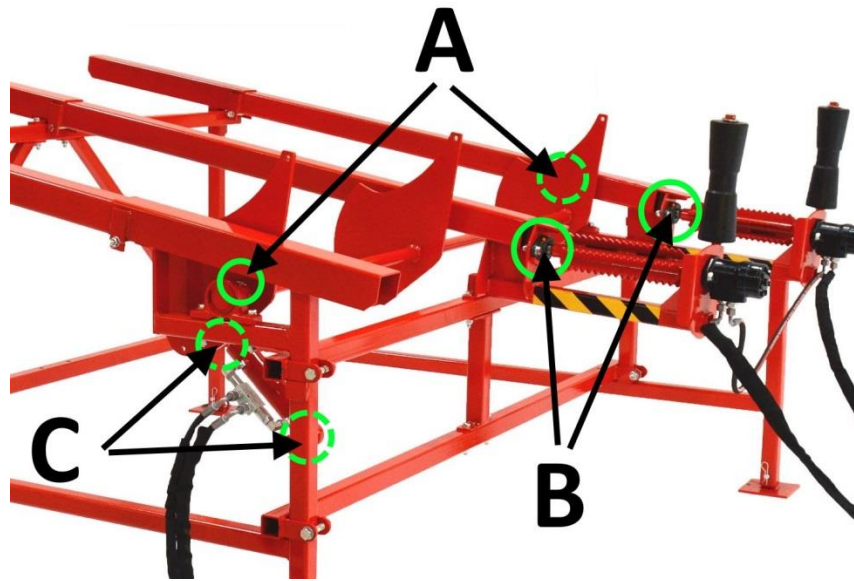

Figure 6



### 5.3. Washing and cleaning

Loose debris and sawdust can be cleaned from the machine with pressurised air, for example. The machine can also be washed with a high-pressure washer as long as the water jet is not aimed directly at the bearings.

Always ensure that the machine and the working area are sufficiently clean during operation. The machine must always be cleaned after use. Clean the machine at suitable intervals and always before storing the machine for a prolonged time. After washing, the machine must be lubricated according to the instructions in Section [5.2](#).

## 6. Storage

Although the machine is intended for outdoor use, it should be covered and stored in a sheltered location or indoors. Before prolonged storage, the machine must first be cleaned, then washed according to Section 5.8 and lubricated according to Section 5.5.

## 7. Maintenance table

Target	Task	Daily	Interval 50 t	Interval 200 h	Substance/accessory item
Lubrication points	Lubrication	<a href="#">Section 5.2</a>	X	X*	Lubrication grease *bearings
Tightening bolts (condition, tightness)	Check	X			
Hoses	Check	X			

## 8. Failures and remedial measures

Failure	Cause	Remedial measure
The in-feed conveyor rollers are not rotating.	<ol style="list-style-type: none"> <li>1. The feed serial connection valve is connected to the machine</li> <li>2. Quick coupling fault or loose coupling</li> <li>3. Incorrect or insufficient valve pressure</li> </ol>	<ol style="list-style-type: none"> <li>1. Open the valve (Figure 3)</li> <li>2. Repair connection</li> <li>3. Contact the retailer</li> </ol>
The feeder is not moving	<ol style="list-style-type: none"> <li>1. Quick coupling fault or loose coupling</li> <li>2. Log stuck</li> </ol>	<ol style="list-style-type: none"> <li>1. Repair connection</li> <li>2. Disconnect from the power source and remove blockage</li> </ol>

## 9. Assembly instructions and spare parts diagrams

### 9.1. Parts list for the assembly

No.	Part number	Name	Standard	Dimensions	Pcs
1	31206	End, cylinder side			1
2	50037432	Rear end			1
3	96044	Retaining ring	DIN 471	30	2
4	31230	Extension			4
5	96208	Hitch pin			4
6	48033	Pin		Ø16 L=135	4
7	48015	Height adjustment pipe			4
8	95003	Keel roller 300			2
9	31059	Log rotator			1
10	11160	Cylinder HF422			1
11	97307	Hydraulic motor HF422			2
12	95057	Collar step bearing unit		UCFL 205	2
13	61105	Drive roller			2
14	50037451	Middle pipe			1
15	50037464	Intermediate support			4
16	50033060	Lock valve HF422			1
17	50037476	Vertical support			1
18	96058	Washer	DIN 125	A12	44
19	96059	Washer	DIN 125	A16	8
20	96054	Washer	DIN 125	A24	2
21	96218	Locking nut	DIN 985	M12	24
22	96219	Locking nut	DIN 985	M16	8
23	96376	Hex screw	DIN 931	M12x80	4
24	96118	Hex screw	DIN 931	M16x90	8
25	96332	Hex screw	DIN 931	M12x130	4
26	96111	Hex screw	DIN 931	M12x90	8
27	96149	Hex screw	DIN 933	M12x45	4
28	96148	Hex screw	DIN 933	M12x40	4
29	96247	Split pin	DIN 94	3.2x40	2
30	50037504	Diagonal support			2
31	97213	USIT 1/2"			4
32	97203	Double nipple 3/8" x 1/2"			4
33	97151	Hydraulic hose 3,800 x 3/8" + quick coupling + guard			3
34	97152	Hydraulic hose 4,500 x 3/8" + quick coupling + guard			1
35	97060	Hydraulic hose 1,200 x 3/8"			1

## 9.2. Assembly phases

**Phase 1:** Assemble in accordance with Figure 7 and leave the screws loose.

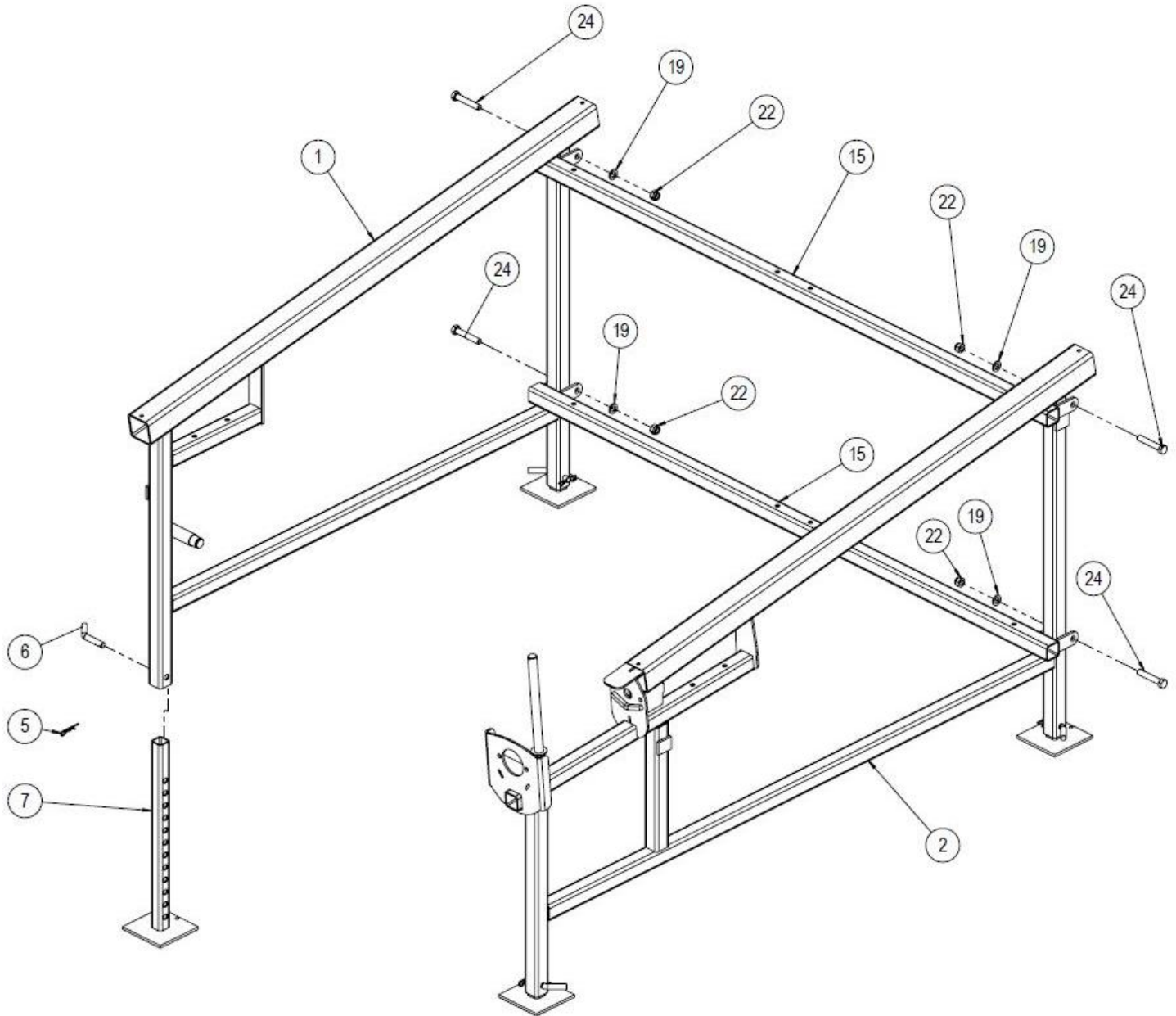

Figure 7

**Phase 2:** Spread the front section. Install feeder 9 first, followed by support pipe 15. Leave the screws loose.

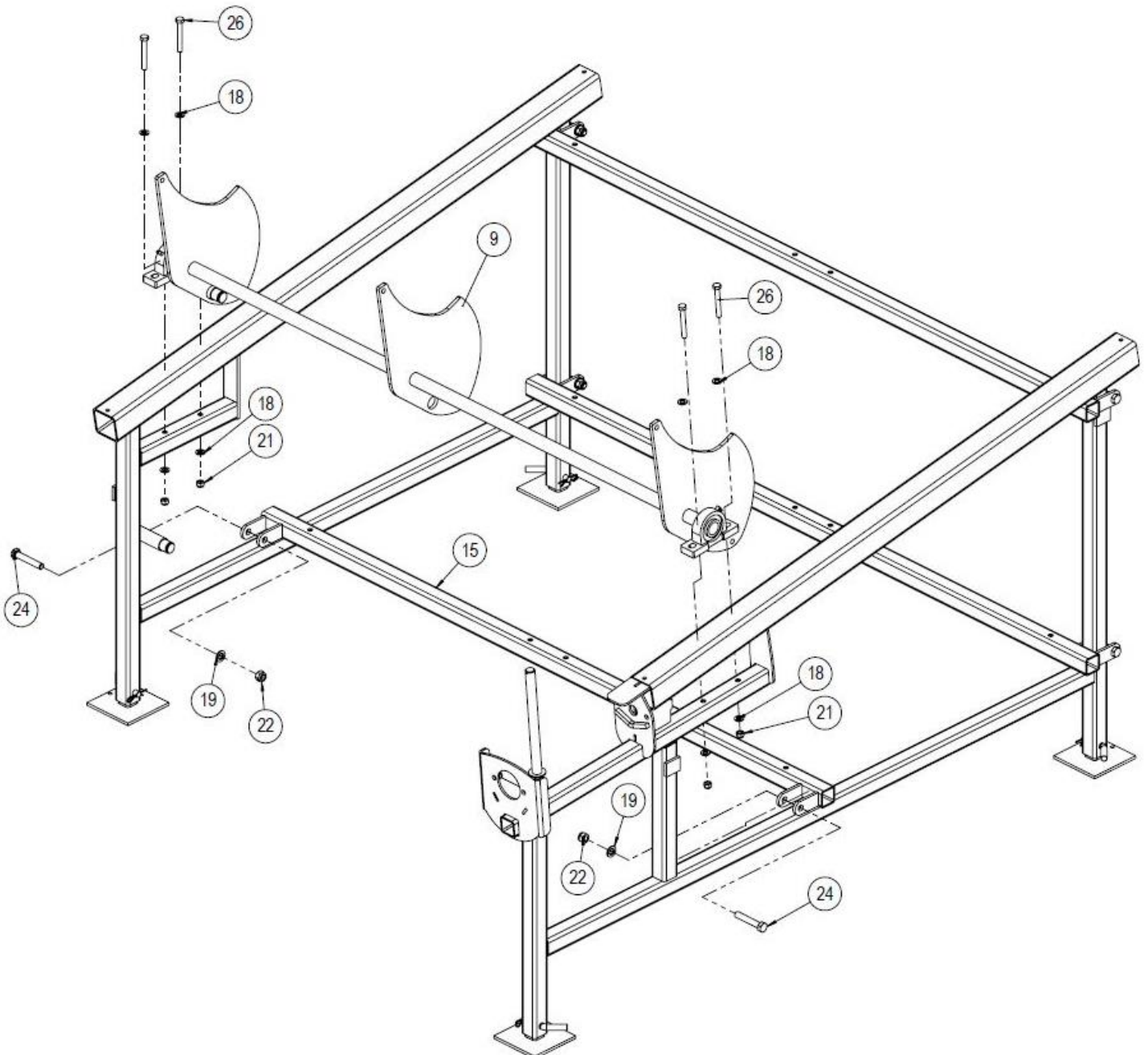

Figure 8

**Phase 3:** Install support 17 first, leave the screws loose. Then install intermediate support 15, leave the screws loose.

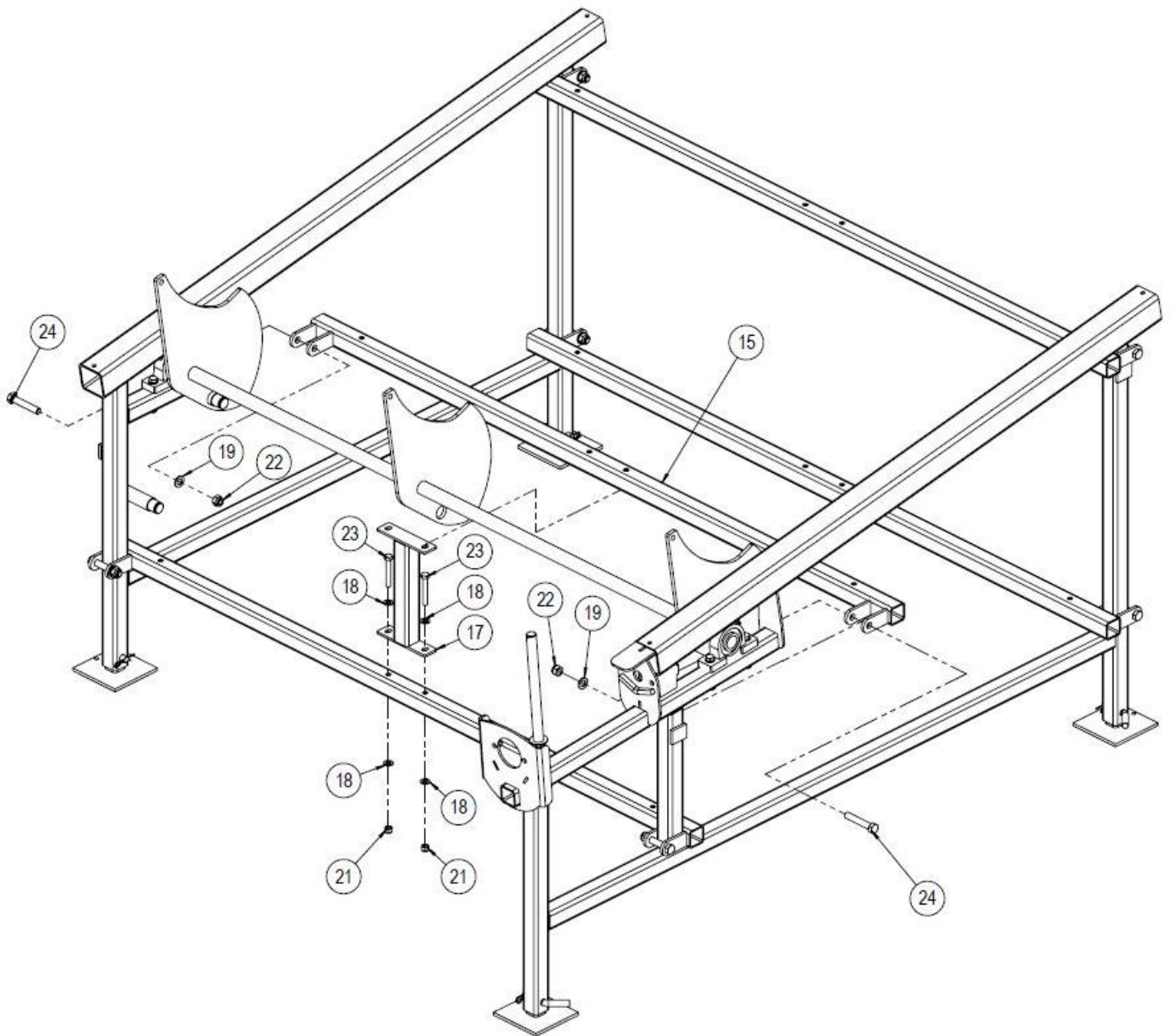

Figure 9

**Phase 4:** First install the No 30 diagonal supports. Fasten the screws to the lower ends and leave them loose. Then install middle pipe 14 and its screws. Leave the screws loose.

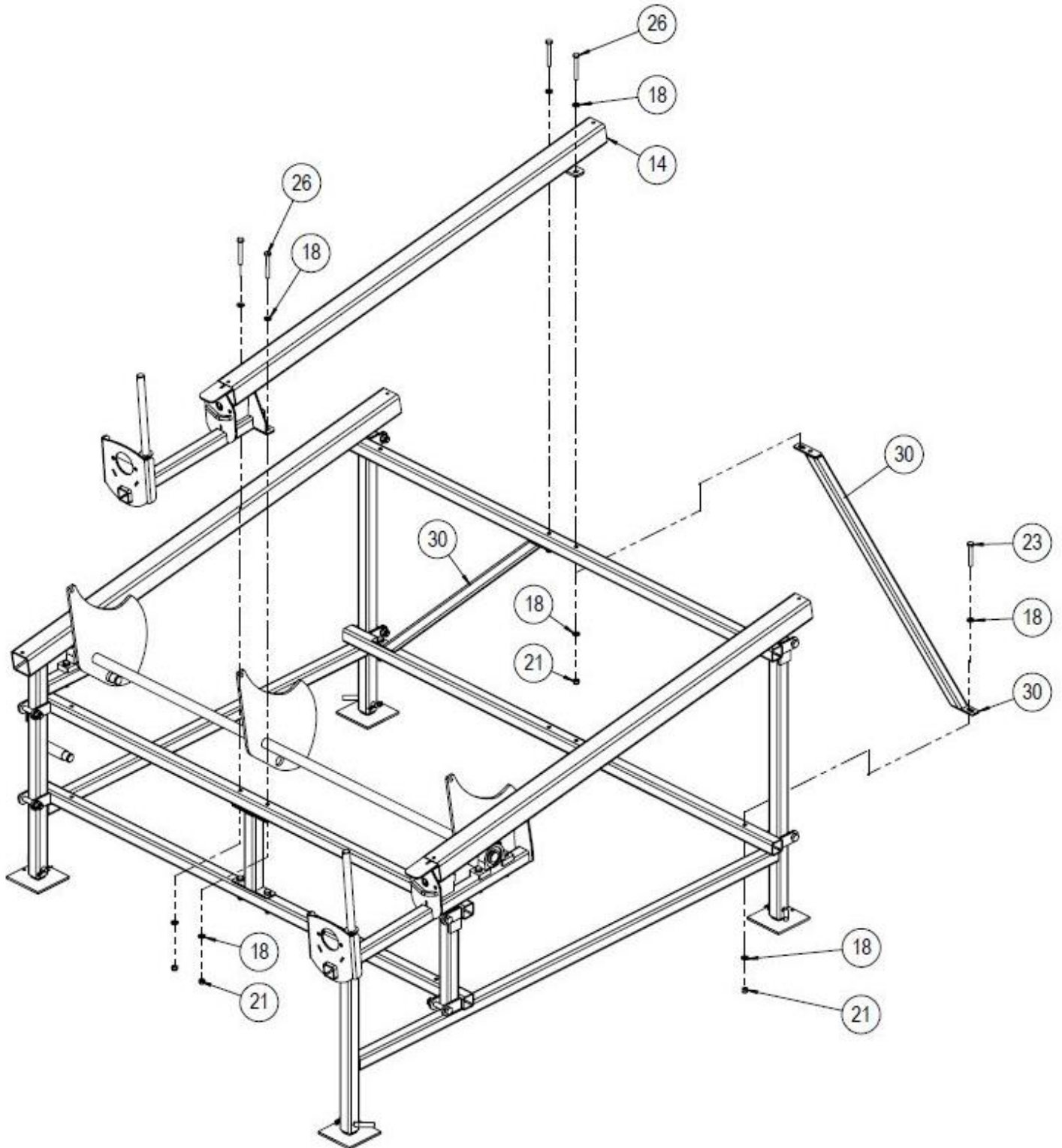

Figure 10



**Phase 5:** Install the cylinder, part 10. Tighten all the screws installed so far.

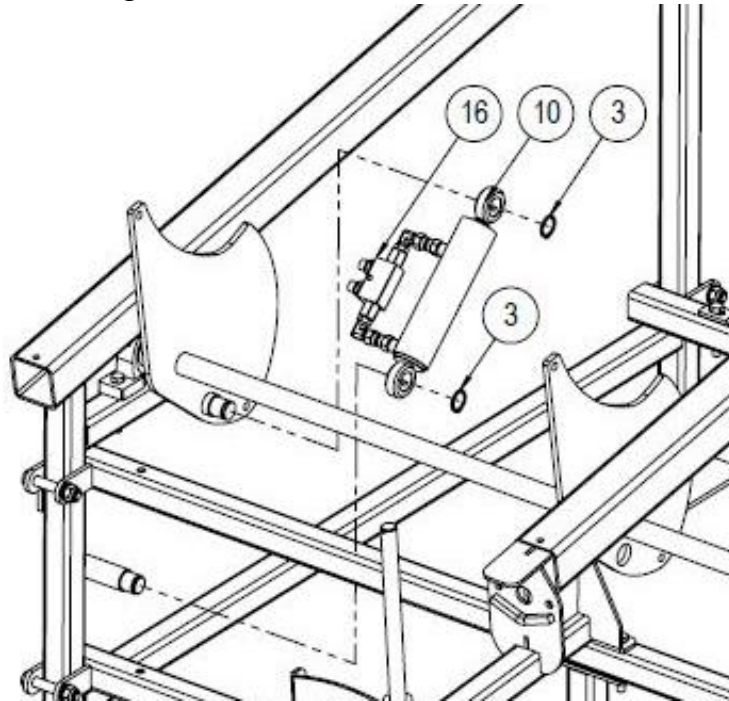

Figure 11

**Phase 6:** Install roller 13; bearing 12 on the end. Leave the screws loose. Then push hydraulic motor 11 into place. Tighten the hydraulic motor screws first, followed by the bearing screws.

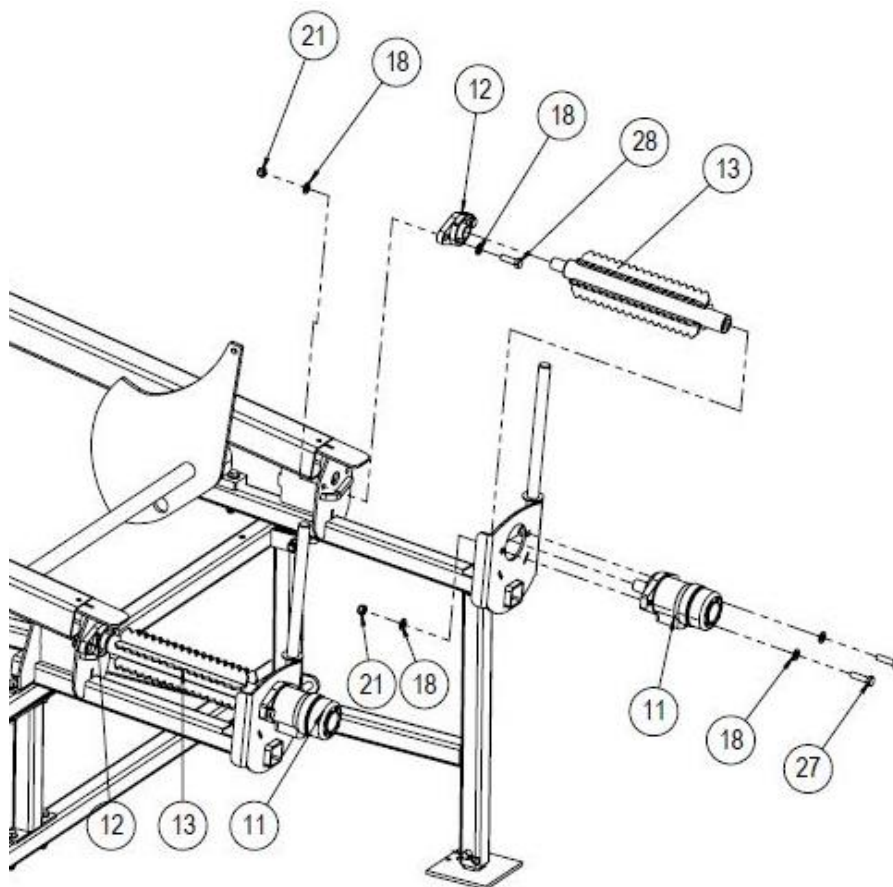
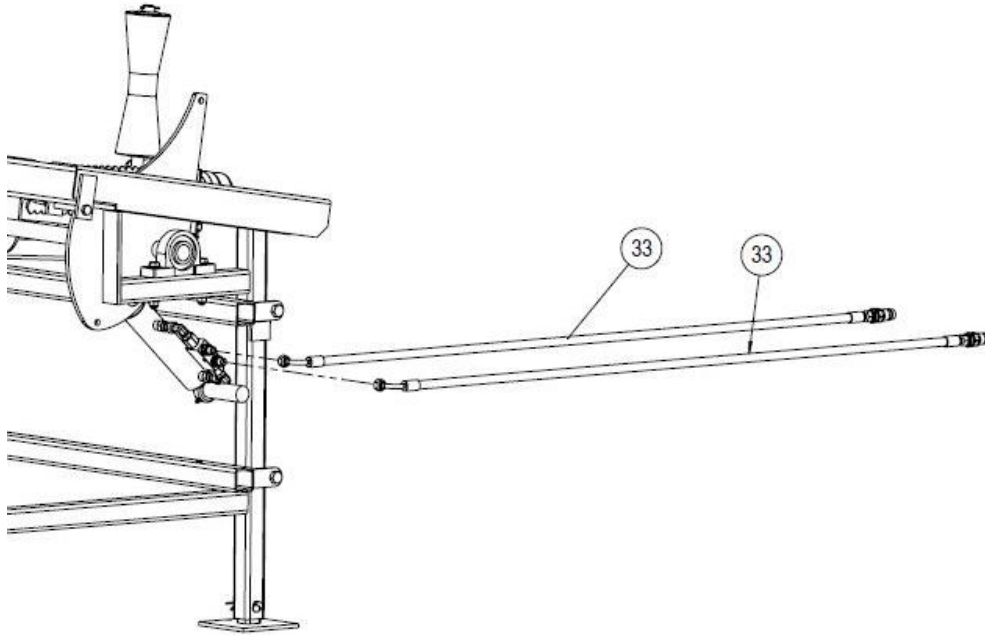

Figure 12



**Phase 7:** Install the No 8 rollers as shown in Figure 13.  
 Install the No 33 cylinder hoses. (Lower marked red, upper black)



*Figure 13*

Install the USIT seals 31, nipples 32 and hydraulic hoses 33 (shorter hose, red) 34 (longer hose, black) and 35 (intermediate hose) in the hydraulic motors.

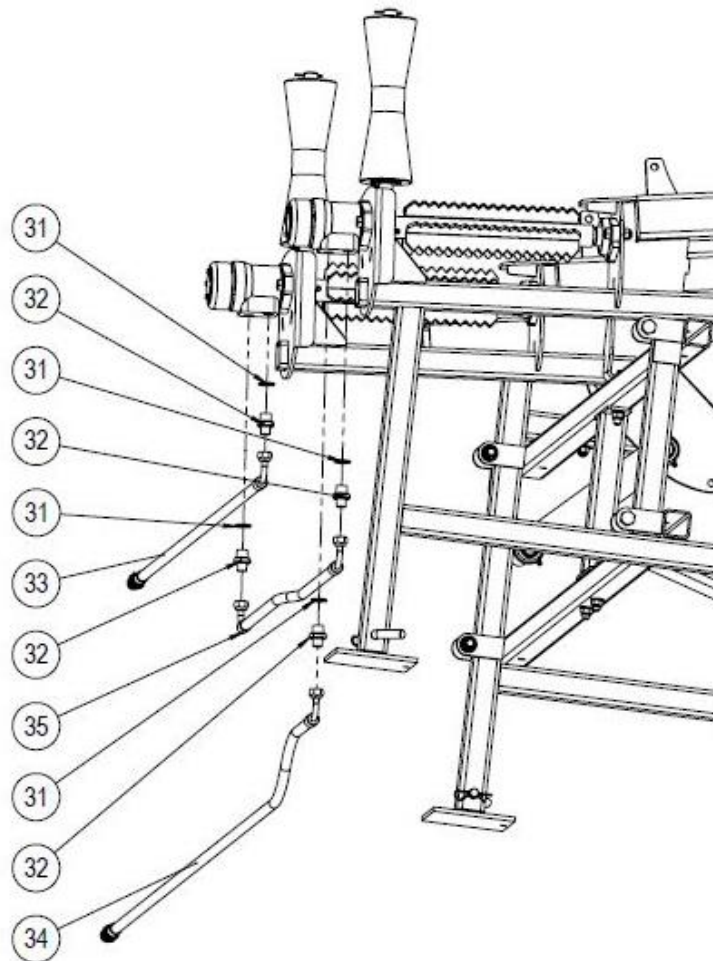

*Figure 14*

**Phase 8:** Install the No 4 extensions and their screws. Tighten the screws. Finish by inspecting the assembly!

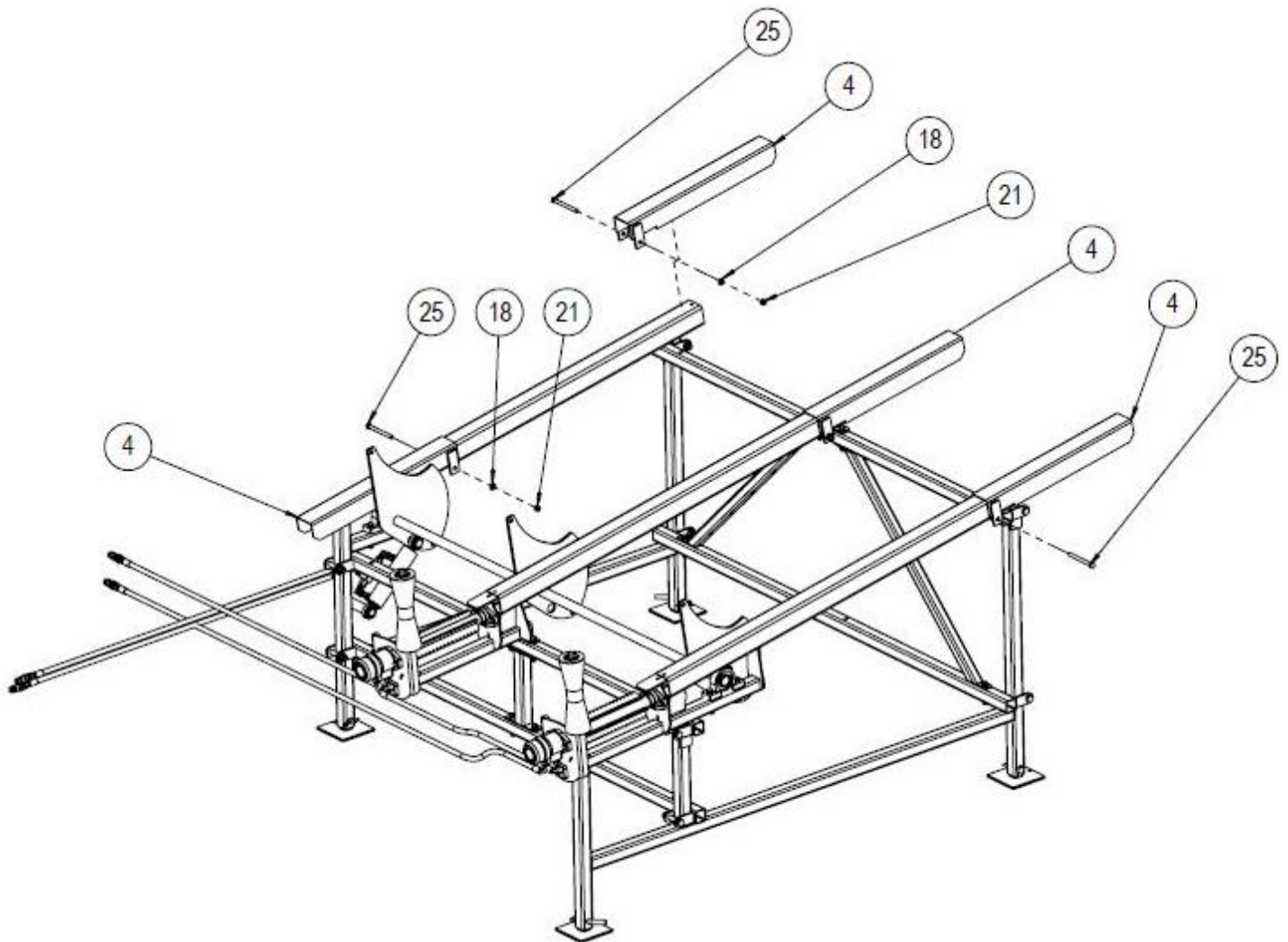

Figure 15

## 10. Guarantee terms

The guarantee is valid for the original buyer for 12 months, starting from the date of purchase, but for no more than 1,000 operating hours.

Always contact the machine's seller before undertaking any procedures in matters concerning the guarantee.

A guarantee claim must be issued to the seller in writing **immediately** upon the discovery of a defect. If the defect concerns a damaged part or component, please send a photograph of the damaged part or component to the seller, if possible, so the fault can be identified. When submitting a guarantee claim, the buyer must always include the type and serial number of the machine in the claim and present a receipt that includes the date of purchase. Guarantee claims must be submitted to an authorised retailer.

### The guarantee covers

- Parts damaged in normal use due to faults in the material or manufacturing.
- Reasonable repair expenses in accordance with the agreement between the seller or buyer and the manufacturer. Faulty parts will be replaced with new ones. A faulty part or parts replaced due to a material fault must be returned to the manufacturer via the retailer.

### The guarantee does not cover

- Damage caused by normal wear and tear (e.g. rollers and wear parts), improper use or use contrary to the instruction manual.
- Damage caused by negligence of maintenance or storage procedures detailed in the instruction manual.
- Damage occurred in transport.
- Normal adjustment, care, maintenance or cleaning measures.
- Defects in a machine to which the buyer has performed or commissioned structural or functional changes, to the degree that the machine can no longer be considered equivalent to the original machine.
- Other potential costs or financial obligations resulting from the procedures mentioned above.
- Indirect costs.
- Travel costs resulting from guarantee repairs.
- The guarantee for parts replaced during the guarantee period of the machine expires at the same time as the machine's guarantee.
- The guarantee is void if the ownership of the machine is transferred to a third party during the guarantee period.
- The guarantee is void if any of the machine's seals have been broken.

If a fault or defect reported by the customer is found not to be covered by the guarantee, the manufacturer has the right to charge the customer for the identification and possible repair of the fault or defect in accordance with the manufacturer's current price list.

This guarantee certificate indicates our responsibilities and obligations in full and excludes all other responsibilities.

## 11. Declaration of incorporation for partly completed machinery

(Machinery Directive 2006/42/EC, Annex II B)

Manufacturer: Maaselän Kone Oy  
Address: Valimotie 1, FI-85800 Haapajärvi

Name and address of the person who is authorised to compile the technical file:

Name: Timo Jussila                      Address: Valimotie 1, FI-85800 Haapajärvi

The aforementioned person assures that

HakkiFeed 422 log rack (Hakki Pilke firewood processor accessory) Serial number: .....

- is compliant with the applicable regulations of the Machinery Directive (2006/42/EC).

This partly completed device may only be connected to a compatible  
Hakki Pilke firewood processor.

Location and date: Haapajärvi, 4 October 2019

Signature: 

*Anssi Westerlund  
Managing Director*